



GRUPO

**Hidrauluc**



- Catálogo de produtos

# CONEXÕES

# ENCAIXE DE SOLDA

- [hidrauluc@hidrauluc.com.br](mailto:hidrauluc@hidrauluc.com.br)
- (31) 3528-6800
- @Hidrauluc
- Acesse nosso site pelo QR code ao lado



# Sobre a

# Hidrauluc

□ Nossa empresa assegura a qualidade de seus produtos e serviços, tendo como estratégia a superação das expectativas de seus clientes, promovendo a saúde e a segurança de suas partes interessadas, de maneira transparente, ética e ambientalmente sustentável. Somos especialistas na distribuição de mangueiras e conectores, além de fabricantes de engates rápidos. Por isso, desenvolvemos projetos especiais para trazer as melhores soluções para nossos clientes.

## □ Informações de código para pedido

### CÓDIGO – MATERIAL INOX

- Para solicitar o material INOX304 ou INOX316L acrescente no final do código 304 ou 316L;

Ex: 10-I-0-09-09-8-8 S6000 304

Ex: 10-I-0-09-09-8-8 S6000 316L

### CÓDIGO – MATERIAL AÇO

- Para solicitar o material AÇO CARBONO 1020 substitua o I pelo A no segundo campo do código

CÓDIGO INOX: 10-I-0-09-09-8-8 S6000

CÓDIGO AÇO CARBONO 1020: 10-A-0-09-09-8-8 S6000

□ HIDRAULUC – LUVA DE ENCAIXE P/ SOLDA – 6000PSI – MATERIAL AISI 304L

CÓDIGO	EXTERNO DO TUBO X PAREDE	D1	D2	D3	L1	L2	ITEM
10-I-0-09-09-8-8 S6000	Ø8 x 1,0	13	8,2	6	30	12	1.1
10-I-0-09-09-10-10 S6000	Ø10 x 1,5	17	10,2	7	35	14	1.2
10-I-0-09-09-12-12 S6000	Ø12 x 1,5	21	12,2	9	35	14	1.3
10-I-0-09-09-16-16 S6000	Ø16 x 2,0	26	16,2	12	40	17	1.4
10-I-0-09-09-20-20 S6000	Ø20 x 2,5	33	20,2	15	40	15	1.5
10-I-0-09-09-25-25 S6000	Ø25 x 3,0	42	25,2	19	45	17	1.6
10-I-0-09-09-30-30 S6000	Ø30 x 4,0	48	30,3	22	45	17	1.7
10-I-0-09-09-32-32 S6000	Ø32 x 4,0	50	32,2	24	45	17	1.8
10-I-0-09-09-38-38 S6000	Ø38 x 5,0	57	38,4	28	50	20	1.9
10-I-0-09-09-42-42 S6000	Ø42 x 5,0	64	42,4	32	50	20	1.10

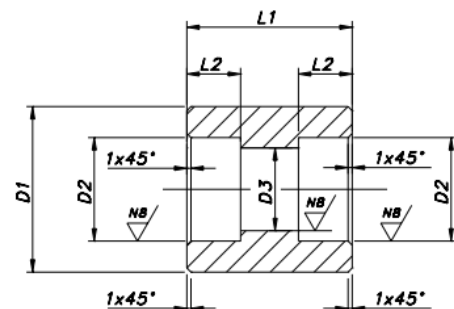

□ HIDRAULUC LUVA DE REDUÇÃO DE ENCAIXE P/ SOLDA – 6000PSI - MATERIAL AISI 304L

CÓDIGO	EXTERNO DO TUBO X PAREDE	D1	D2	D3	D4	D5	L1	L2	L3	ITEM
10-I-0-09-09-16-10 S6000	Ø16 x 10	24,8	16,2	12	7	10,2	29,1	10	10	2.1
10-I-0-09-09-20-10 S6000	Ø20 x 10	32,8	20,2	15	7	10,2	32,1	13	10	2.2
10-I-0-09-09-20-15 S6000	Ø20 x 15	32,8	20,2	15	11	15,2	32,1	13	10	2.3
10-I-0-09-09-22-15 S6000	Ø22 x 15	34,8	22,2	15	11	15,2	32,1	13	10	2.4
10-I-0-09-09-22-10 S6000	Ø22 x 20	34,8	22,2	15	15	20,2	32,1	13	10	2.5
10-I-0-09-09-22-20 S6000	Ø22 x 20	37,8	25,2	19	11	15,2	32,1	13	10	2.6
10-I-0-09-09-25-16 S6000	Ø25 x 16	37,8	25,5	19	12	16,2	32,1	13	10	2.7
10-I-0-09-09-25-20 S6000	Ø25 x 20	37,8	25,2	19	15	20,2	32,1	13	12	2.8
10-I-0-09-09-25-20 S6000	Ø25 x 22	37,8	25,2	19	15	22,2	38,1	14	12	2.9
10-I-0-09-09-38-20 S6000	Ø38 x 20	53,8	38,2	28	15	20,2	38,1	14	12	2.10
10-I-0-09-09-38-25 S6000	Ø38 x 25	53,8	38,2	28	19	25,2	38,1	14	13	2.11
10-I-0-09-09-38-30 S6000	Ø38 x 30	53,8	38,2	28	22	30,2	38,1	14	14	2.12
10-I-0-09-09-42-25 S6000	Ø42 x 25	58,0	42,3	32	19	25,2	38,1	14	14	2.13
10-I-0-09-09-42-30 S6000	Ø42 x 30	58,0	42,3	32	22	30,2	38,1	14	14	2.14
10-I-0-09-09-42-38 S6000	Ø42 x 38	58,0	42,3	32	28	38,2	38,1	14	14	2.15
10-I-0-09-09-48-25 S6000	Ø48 x 25	67,1	48,5	34,1	19	25,2	38,1	14	14	2.16
10-I-0-09-09-48-30 S6000	Ø48 x 30	67,1	48,5	34,1	22	30,2	38,1	14	14	2.17
10-I-0-09-09-76-73 S6000	Ø76 x 73	96,0	76,3	56,1	54	73,2	51,0	16	16	2.18

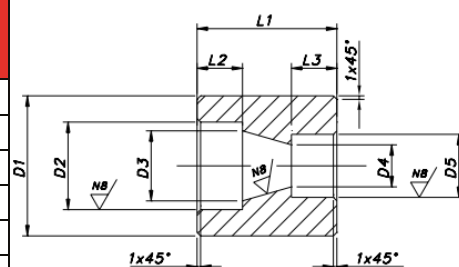

□ HIDRAULUC – TÊ DE ENCAIXE P/ SOLDA – 6000PSI – MATERIAL AISI 304L

CÓDIGO	EXTERNO DO TUBO X PAREDE	D1	D2	D3	L1	L2	ITEM
10-I-3-09-09-10-10-10 S6000	Ø10 x 1,5	15,8	10,2	7	20,5	9,5	4.1
10-I-3-09-09-16-16-16 S6000	Ø16 x 2,0	25	16,2	12	23,5	10	4.2
10-I-3-09-09-20-20-20 S6000	Ø20 x 2,5	30,6	20,22	15	29	13	4.3
10-I-3-09-09-25-25-25 S6000	Ø25 x 3,0	37	25,2	19	32	13	4.4
10-I-3-09-09-30-30-30 S6000	Ø30 x 4,0	50,2	30,3	22	40	14	4.5
10-I-3-09-09-38-38-38 S6000	Ø38 x 5,0	53,5	38,3	28	40	14	4.6
10-I-3-09-09-42-42-42 S6000	Ø42 x 5,0	53,5	42,3	32	40	14	4.7

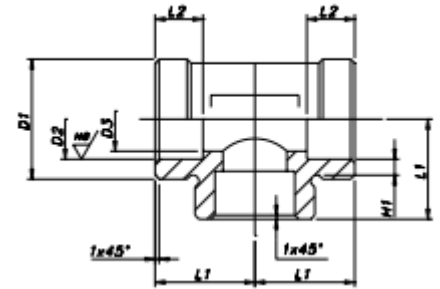

□ HIDRAULUC – JOELHO 90° DE ENCAIXE P/ SOLDA – 6000PSI - MATERIAL AISI 304L

CÓDIGO	EXTERNO DO TUBO X PAREDE	D1	D2	D3	L2	ITEM
10-I-9-09-09-10-10 S6000	Ø10 x 1,5	15,8	10,2	7	9,5	5.1
10-I-9-09-09-16-16 S6000	Ø16 x 2,0	25	16,2	12	10	5.2
10-I-9-09-09-20-20 S6000	Ø20 x 2,5	30,6	20,2	15	13	5.3
10-I-9-09-09-25-25 S6000	Ø25 x 3,0	37	25,2	19	13	5.4
10-I-9-09-09-30-30 S6000	Ø30 x 4,0	50,2	30,3	22	14	5.5
10-I-9-09-09-38-38 S6000	Ø38 x 5,0	53,5	38,3	28	14	5.6
10-I-9-09-09-42-42 S6000	Ø42 x 5,0	53,5	42,3	32	14	5.7

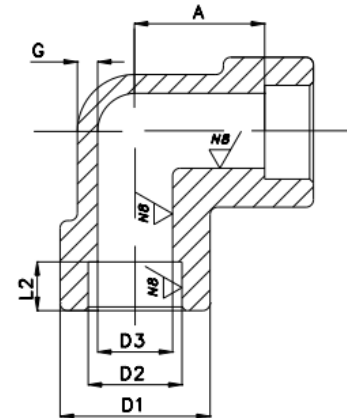

□ HIDRAULUC – TAMPÃO DE ENCAIXE P/ SOLDA - 6000PSI - MATERIAL AISI 304L

CÓDIGO	EXTERNO DO TUBO X PAREDE	D1	D2	L2	ITEM
10-I-0-102-09-10 S6000	Ø10 x 1,5	15,8	10,2	9,5	3.1
10-I-0-102-09-16 S6000	Ø16 x 2,0	25	16,2	10	3.2
10-I-0-102-09-20 S6000	Ø20 x 2,5	30,6	20,2	13	3.3
10-I-0-102-09-25 S6000	Ø25 x 3,0	37	25,2	13	3.4
10-I-0-102-09-30 S6000	Ø30 x 4,0	50,2	30,3	14	3.5
10-I-0-102-09-38 S6000	Ø38 x 5,0	53,5	38,3	14	3.6
10-I-0-102-09-42 S6000	Ø42 x 5,0	53,5	42,3	14	3.7

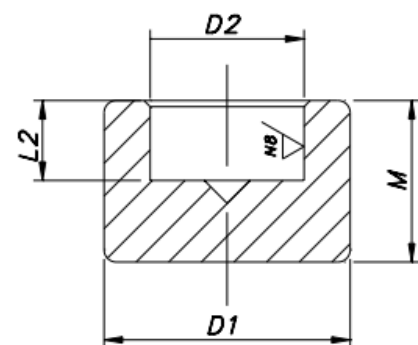

# GRUPO Hidrauluc

---



---

Mangueiras e Conexões Hidráulicas

---



Rua da Luz, 87 | Vila Paris  
Contagem – MG | CEP: 32372-130



(31) 3528-6800 | (31) 98315-7520



hidrauluc@hidrauluc.com.br

---

*Siga nossas redes sociais*

---

